

PUBLIC COMPANY ORLEN LIETUVA

APPROVED BY:
Director of Quality, Labour Safety and
Environmental Control

18 October 2024
Order No TV1(1.2-1)-2024-0444

OCCUPATIONAL HEALTH AND SAFETY PROCEDURE BDS-11 WORK AT HEIGHT

I. GENERAL

Purpose and Scope of Application

1. The purpose of Occupational Health and Safety Procedure BDS-11 – Work at Height (hereinafter – the Procedure) is to establish occupational health and safety (OHS) requirements for use of fall protection or access protective equipment at Public Company ORLEN Lietuva (hereinafter – the Company).

2. This Procedure applies to all Company's and contractor's (if so prescribed by the contract concluded between contractor and the Company) employees who organize and plan work at height, also for those who execute or access work at height with fall protection equipment.

II. REFERENCES

3. This Procedure has been developed in line with effective revisions of the following documents:

3.1. Guidelines on Establishment of Workplaces on Construction Sites as approved by the Minister of Social Security and Labor of the Republic of Lithuania and the Minister of Environment of the Republic of Lithuania;

3.2. General Regulations on Usage of Work Equipment approved by the Minister of Social Security and Labor of the Republic of Lithuania.

3.3. Maintenance Manual of Mobile Work Platform Lifts approved by the Minister of Social Security and Labor of the Republic of Lithuania.

3.4. General Rules for the Installation of Electrical Equipment approved by the Minister of Energy of the Republic of Lithuania;

3.5. LST EN 12811-1:2006 temporary works equipment - Part 1 - Scaffolds - Performance requirements and general design;

3.6. LST EN 1004-1:2021 Mobile access and working towers made of prefabricated elements - Part 1 - Materials, dimensions, design loads, safety and performance requirements;

3.7. LST EN 131-1:2015+A1:2019 Ladders - Part 1 - Terms, types, functional sizes;

3.8. LST EN 131-2:2010+A2:2017 Ladders - Part 2 - Requirements, testing, marking;

3.9. LST EN 131-3:2018 Ladders - Part 3: Marking and user instructions;

3.10. LST EN 131-4:2020 Ladders - Part 4: Single or multiple hinge-joint ladders;

3.11. LST EN 131-6:2019 Ladders - Part 6: Telescopic ladders;

3.12. LST EN 131-7:2013 Ladders - Part 7: Mobile ladders with platform;

3.13. LST EN ISO 14122-3:2016 Safety of machinery - Permanent means of access to machinery - Part 3 - Stairs, stepladders and guard-rails;

3.14. LST EN ISO 14122-4:2016 Safety of machinery - Permanent means of access to machinery - Part 4 - Fixed ladders;

3.15. LST EN 353-1:2014+A1:2018 Personal fall protection equipment - Guided type fall arresters including an anchor line - Part 1 - Guided type fall arresters including a rigid anchor line;

3.16. LST EN 353-2:2003 Personal protective equipment against falls from a height - Part 2 - Guided type fall arresters including a flexible anchor line EN 354 (lanyards);

3.17. LST EN 355:2003 Personal protective equipment against falls from a height - Energy absorbers;

3.18. LST EN 358:2019 Personal protective equipment for work positioning and prevention of falls from a height - Belts for work positioning and restraint and work positioning lanyards;

3.19. LST EN 360:2024 Personal protective equipment against falls from a height - Retractable type fall arresters;

3.20. LST EN 362:2005 Personal protective equipment against falls from a height - Connectors;

3.21. PKN ORLEN S.A. Standard S4 - Work at height;

3.22. PKN ORLEN S.A. Standard S7 - Adaptation of machines and tools to ensure safe operation in working environments.

III. TERMS, DEFINITIONS AND ABBREVIATIONS

4. Terms used herein shall be defined as follows:

Fall protection equipment – all equipment designed to protect employees against fall from height (scaffolds, ladders, mobile work platform lifts and personal fall protection equipment).

Personal fall protection equipment (hereinafter – **PFPE**) – system designed for work positioning/travel restraint or arrest fall from height. The key elements of this system (Fig. 1): body wear (full-body harness) (1), fall arrester (self-retracting life-line, energy absorber, etc.) (2), connectors (snap hooks (3) and hooks (4)) and ropes (5).



Fig.1. Fall protection equipment

Work restraint PFPE – personal work positioning system with self-retracting life-line arranged so that it is not possible for the user to access zones where the risk of a fall exists.

Work positioning PFPE – personal fall arrest system that limits the distance of free fall while working on elevated vertical surfaces with energy absorber which reduces the impact force (below 600 N) and the risk of injuries for the operator.

Periodic inspection of PFPE – obligatory inspection of the technical condition of personal fall protection equipment performed at established intervals which includes identification and evaluation of regulatory compliance.

Scaffold inspector – an employee appointed by a scaffolding company, duly trained according to procedure established by the scaffolding company, holds an evidence of his/her qualification, is responsible for inspection of scaffolds and decision whether to allow works on them according to the procedure established herein.

Work at height – any work performed over one meter above the ground/floor level where the risk of fall down to a lower level exists, unless fall protection equipment is used.

Work coordinator – employee of Company organizational unit that initiates the erection of scaffolds ordered by the Company or employee of contractor that initiates the erection of scaffolds ordered by the contractor.

Horizontal safety system – fall arrest system consisting of horizontal steel or fiber lines fixed at two anchoring points with a tensioning device which is designed to connect other fall protection equipment used by an employee (Fig. 2).



Fig. 2. Examples of horizontal safety systems

Competent person (natural or legal) – PFPE manufacturer, a person trained and authorized by PFPE manufacturer or enterprise which meets the requirements of legal acts and holds documents entitling to perform periodic inspections of PFPE and to decide on the suitability of inspected equipment for further safe use and to issue documents evidencing the findings of inspections.

Ladder – fixed or portable piece of work equipment which is used as means for access or moving from one level to another.

Mobile Elevating Work Platform (MWP) – equipment consisting of work platform assembly, controllers, elevation mechanism and wheelbase designed to elevate employees for work in the platform at height. Depending on the type of base, the MWP can be either self-propelled or non-self-propelled.

Scaffold – temporary elevated platform (supported or suspended) and its supporting structure used for supporting employees and materials and protect both against fall from height (diagram with typical elements is shown in Annex 1).

Scaffold user – an employee using scaffold for work and/or access.

Scaffold inspection card – card filled in by a scaffolder where main data about the scaffold is provided (Annex 3).

Scaffold design – a document containing scaffold installation instructions and calculations proving and/or confirming that, once installed as instructed, the scaffolds will be safe for use at design loads.

Scaffold designer – a legal or natural person certified by certification body for development of scaffold installation designs.

Scaffolding company – contractor which installs, modifies (replaces) and/or demounts scaffolds in the territory of the Company.

Scaffolder – an employee installing, modifying (replacing) and/or demounting scaffolds, duly trained according to procedure established by the scaffolding company and holding a document proving this (certificate, etc.).

Vertical safety system – fall arrest system consisting of a rigid vertical line (steel rail, line or rope) fixed at two anchoring points with a tensioning device designed to connect other equipment used by an employee for protection against fall (Fig. 3).



Fig. 3. Vertical safety system

IV. POTENTIAL HAZARDS

5. When accessing and/or executing work at height the following hazards can occur:

5.1. **Fall from height** due to incorrect installation/demounting of scaffolds, open gaps, inappropriately installed or missing guard rails on work platforms, displacement of scaffolds or ladder due to improper base (e.g., slippery or too soft), work platform or ladder failure due to excessive loads, improper use or damage, failure to use or misuse of PFPE;

5.2. **Fall of objects** due to inappropriately installed or missing toe boards, tools or materials kept improperly on scaffolds, etc.;

5.3. **Fall on same level** due to messy and/or dirty surface of work platform;

5.4. **Electric shock** upon contact with an electric conductor or metal part of scaffolds while working with electric tools on non-grounded scaffolds;

5.5. **Concussion** (e.g., head injuries if hit against rigid structural elements);

5.6. **Uncomfortable posture, prolonged standing and tension** while working on ladder.

V. DUTIES AND RESPONSIBILITIES OF EMPLOYEES

Installation and use of scaffolds

6. Work coordinator must:

6.1. When ordering installation of scaffolds the following data must be indicated: scaffolds installation location, scaffolds load class, scaffolds working platform installation height and dimensions (length and width). Load class 2 is usually indicated for working on scaffolds. Where need arises to use higher loads on scaffolds, the work coordinator must coordinate this with the scaffolding company and specify a higher class in the order;

6.2. Indicate the location of construction to the scaffolders and make sure that scaffolds do not obstruct access to process units and fire-fighting equipment;

6.3. After installation check if scaffolds have been installed according to the data indicated in order;

6.4. In case of any drawbacks or irregularities identified during inspection, request the responsible manager of scaffolding company and/or person inspecting the scaffolds to eliminate any irregularities and accept only the correctly installed scaffolds.

7. A scaffolding company must:

7.1. When installing scaffolds, observe requirements prescribed by manufacturer for installation, inspection, testing of scaffold as well as legal acts and standards effective in the Republic of Lithuania applicable to installation and use of scaffolds;

7.2. Develop scaffolds design according to requirements prescribed by manufacturer in cases established herein and in cases prescribed by manufacturer;

7.3. Register all installed scaffolds indicating the number of registration, location and date, also the inspection dates and the details of scaffold inspectors after installation of scaffolds and their periodic inspections;

7.4. Assign persons responsible for scaffold inspections and submit the list of these persons to the Company's Occupational and Process Safety Control Department.

8. A scaffolds user must:

8.1. Prior to using the scaffolds, make sure that the scaffolds have a scaffold inspection card displayed on them and read the following entries in the card: bearing load, location and date of installation (if more than 10 days since installation, make sure the card has a valid entry on periodic inspection), also take into account all entries made in the scaffold inspection card and follow OHS requirements while working on the scaffolds;

8.2. In case of use of electric tools on scaffolds, organize the grounding of scaffolds following the procedure established herein;

8.3. Avoid any additional loads on scaffolds (e.g., attachment of winches, hoists to scaffold structure to lift materials onto a working platform, etc.), unless agreed with the scaffolding company. Where need arises to use scaffolds with a load class higher than 2, inform the work coordinator thereof;

8.4. Even if scaffold inspection card allowing to work on the scaffold assembly is present, check the scaffold for good condition and reliability, also remove any unnecessary objects, clean snow or ice, if any, from work platforms;

8.5. Not reassemble the scaffold or remove any structural elements;

8.6. If scaffolds are not safe, do not comply with the requirements prescribed in this Procedure or other normative documents and pose danger to people working on or near them, suspend works on the scaffolds, report to work manager and remove scaffold inspection card. Resume works on scaffolds only after all irregularities are removed and scaffold is re-inspected by a scaffold inspector.

Use of PFPE and ladders

9. Manager of employees who use PFPE and ladders for work at height must:

9.1. After evaluation of workplace risks, select necessary PFPE and other personal protective equipment for employees;

9.2. Ensure maintenance of the assigned PFPE and/or ladder in accordance with manufacturer operation and maintenance instructions, this Procedure, legal acts of the Republic of Lithuania and the Company normative documents, including keeping records of PFPE and/or ladder and organizing their inspection, testing and tagging;

9.3. Organize familiarization of employees using PFPE and/or ladders with the instructions for their use and maintenance and, where necessary, training;

9.4. Ensure that PFPE and/or ladders are not used if they do not have declaration of conformity (PFPE must also have CE marking and supporting documents), instructions for use and maintenance, no PFPE and/or ladder inspection has been performed or inspection found that PFPE and/or ladder is unsuitable for further safe use;

9.5. Ensure that employees use PFPE and/or ladders according to the manufacturer's requirements and this Procedure;

9.6. Ensure the good functioning and proper hygienic condition of PFPE by organizing the necessary maintenance, repair or replacement;

9.7. Control that employees use PFPE issued to them throughout the work process when the use of these devices is necessary.

10. Employees who use PFPE and ladders for work at height must:

10.1. Follow the requirements set by the manufacturer and those prescribed herein (scope of inspection prior to use, intervals between periodic mandatory inspections, instructions for maintenance and storage);

10.2. Prior to ascending, visually inspect the ladder for any defects, and make sure it is fully assembled;

10.3. Prior to each use of PFPE, visually check it to make sure PFPE has been periodically inspected, that safety harnesses, life-lines are clean, without any tears, abrasions or burns, that snaps, hooks are in proper shape, etc.;

10.4. If a ladder defect is determined or PFPE is found to be unsuitable for use during a visual inspection, label them as shown in Annex 7 thereto and remove the unsuitable device from the workplace.

VI GENERAL REQUIREMENTS

11. Access equipment for work at height shall be selected according to frequency and duration of use as well as the height to be accessed. Selected equipment must be fit for evacuation in case of an inevitable hazard.

12. When selecting, priority shall be given to scaffolds and MWP as these means are considered to be among the safest for work at height.

13. Use of ladder for work at height is allowed only when the use of any other safer equipment would be unreasonable due to low risk and short duration of use.

14. It is prohibited to use any means which are inherently not designed for access and work at height (boxes, drums, etc.).

15. Where the risk cannot be prevented or limited to a sufficient degree with collective protective equipment or where arrangement of such equipment is inexpedient, PFPE shall be used.

16. Work at height is allowed only when weather conditions do not pose any danger to health and safety of employees.

17. Permits for work at height shall be issued as prescribed by the following Company's OHS Procedures:

17.1. Occupational Health and Safety Procedure BDS-5 Cold Repair Works;

17.2. Occupational Health and Safety Procedure BDS-6/1 Equipment Depressurization Works;

17.3. Occupational Health and Safety Procedure BDS-6/2 Works in Confined Spaces;

17.4. Occupational Health and Safety Procedure BDS-7 Hot Works;

17.5. Occupational Health and Safety Procedure BDS-31 Earth Works.

VII. SCAFFOLDS

Requirements for installation

18. Only certified scaffolds shall be installed at the Company, i.e. those manufactured according to specifications recognized by the standardization institution (European Committee for Standardization (CEN), Technical Committee of the Lithuanian Standards Board (TC LSB), etc.) as well as relevant standards applied to them [3.5, 3.6]. Such scaffolds shall have manufacturer's user manuals, typical scaffold installation designs.

19. A separate design for installation shall be developed:

19.1. If it is required to install scaffolds otherwise than prescribed by manufacturer, i.e. otherwise than shown in typical (standard) design;

19.2. If the scaffold assembly is over 24 meters tall;

19.3. In cases prescribed by the manufacturer.

20. All scaffolds shall be installed, inspected and maintained so as to prevent their falling or displacement, assuring stability of scaffolds – attaching a scaffold to a stable load-bearing structure, installing an additional scaffold support structure with a wider base, attaching additional support and adjustable support plate to a concrete surface or any other methods recommended by manufacturers to assure the stability of scaffolds.

21. If it is impossible to fix scaffolds to a stable metal or reinforced concrete supporting structure, the height of work platform on detached scaffold shall be maximum 3 times the minimum base dimension for outdoor scaffolding and 4 times the minimum base dimension for indoor scaffolding (e.g., if the width of work platform b_s is 0.7 m, the maximum height of scaffold assembly h_s (Annex 1) shall be $0.7 \times 3 = 2.1$ m for outdoor scaffold and $0.7 \times 4 = 2.8$ m for indoor scaffold).

22. Installed scaffolds cannot obstruct access to process units and fire-fighting equipment.

23. Work platforms must be of such size and used in such way as to ensure reliable protection of employees against fall from height and against fall of objects. Metal decks are recommended for installation of work platform. At least 15 cm high toe boards must be installed around the edges of work platform to protect against accidental fall of objects down to lower levels and guard rails consisting of at least two crossbars (top and mid rail) arranged horizontally at appropriate height. The height of the top rail shall be at least 1 m. The distance between the horizontal rails shall not exceed 0.5 m.

24. Scaffolds and work platforms must be installed for maximum expected loads in consideration of the nature of works and actual loads (Annex 4).

25. In case of need to place any additional loads on scaffold decks, respective calculations must be made and assembly must be verified for such loads.

26. Scaffolders must use fall protection equipment. For work positioning, scaffolders must use two lines with hooks (the second hook must be coupled to respective anchoring point before uncoupling the first one). Tools for scaffold installation must be kept in special belts with pockets and integral lanyards. Tools must be secured against fall from height by means of lanyards.

27. Before installing, scaffolders must:

27.1. Ensure that dangerous area is protected against any unauthorized access as prescribed by the Company's OHS Procedure BDS-20 'Enclosures';

27.2. Check all scaffold elements for any cracks, dents, deformations, damage to bolt threads, etc.;

27.3. Make sure the surface for installation or attachment of scaffolds is firm and stable, the ground is even, compact and has a slope to drain surface waters. If scaffolds are installed on stationary platforms, take technical characteristics of such platforms and additional loads into account.

28. Base plates with sills must be placed on additional supports (e.g., wood boards) to distribute the load of scaffold assembly onto larger area. Additional supports may be not used when scaffolds are installed on even, crumble-free concrete surface.

29. The first horizontal frame of ledgers and transoms shall be assembled at maximum height of 25 cm over the base plates (Fig. 4). If ledger or transom cannot be mounted due to some obstacle (pipeline, curb, etc.), it may be coupled to a higher coupler.



Fig. 4. Assembly of the first horizontal frame

30. All access points to unfinished scaffolds must be immediately labelled clearly stating that the use of scaffolds is prohibited (see Annex 5 for examples of prohibition labels).

31. Gaps between separate decks, also between the deck and a toe-board must be as small as possible, to the maximum of 25 mm.

32. Means for access to higher levels (ladders or staircases) shall comply with the requirements set in the standards [3.8, 3.9], and be installed according scaffold manufacturer's requirements (see Fig. 5 for example). The length of ladders should not exceed 3 meters.



Fig. 5. Examples of installed access means

33. Staircases shall be used for intensive work where scaffold users have to descend and ascend frequently, take materials, tools, etc. onto and off a work platform.

34. When access to work platform is arranged inside the scaffolding structure, decks with lockable hatches shall be installed to keep access ports closed and prevent accidental fall of scaffold users down onto lower levels.

35. When access to the working platform is arranged outside the scaffolding structure, the gates shall be installed for access on the working platform.

36. Means for access to higher levels must be stable, protected against loosening or displacement, and have non-slippery surface. Inclination angle for staircases is from 30° to 55°, for ladders – 65° to 75°.

37. For work on 6 m or higher scaffolds, at least two decks must be installed: work (top) deck and safety (bottom) deck, maximum 2 m below the work deck.

38. If scaffold structure is long, at least every 40 meters scaffold access points must be installed and maximum distance from the furthest point of work to the nearest scaffold access point must be 20 m, i.e. at least two access points must be available.

39. In areas of intense traffic where a risk of fall of objects exists, scaffolds must be covered up with, e.g. net, canvas, reinforced film, etc.

40. If electric tools are going to be used on metal scaffolds, the scaffolds must be grounded following the requirements hereof [3.5].

41. No additional grounding is needed where scaffolds are connected with sleeve couplers to natural grounding, i.e. metal or ferroconcrete structures which have the required contact with the ground, water supply and any other metal pipelines laid in the ground (except for pipelines containing combustible liquids, gases and explosive products), metal hydro-technical structures and installations.

42. If the distance between a scaffold structure and a wall does not exceed 15 cm, guard rails on the side facing the wall are not necessary.

43. If scaffold structure protrudes into a roadway, the following shall be done to ensure safety of road users (vehicles and pedestrians):

43.1 Respective traffic signs (e.g., dangerous works, speed limit, road narrowing, no entry, etc.) must be placed;

43.2. Scaffold elements must be marked with reflective yellow/black or white/red tapes.

44. Additional requirements for mobile scaffolds:

44.1. Maximum allowable height outdoors – 8 m, indoors – 12 m;

44.2. Wheels must be solid, equipped with dual locking mechanism to block any displacement and movement.

45. Scaffolds must be installed so as to ensure safety and health of workers and so that use of personal fall protection equipment was not required.

46. If safe installation of scaffolds is obstructed by pipelines or any other structures, before the use of scaffolds certain arrangements must be done to remove any risks of fall from height (e.g., if it is impossible to install gates for access on the working platform, additional crossbars from scaffold elements to protect against direct access to side opening must be installed, etc.). If due to technical reasons it is impossible to enclose dangerous areas, the scaffolders must mark such areas with OHS signs 'Risk of Fall', 'Risk of Falling Objects' and in scaffold inspection card mark 'Dangerous places marked', 'Use fall protection equipment'.

47. Outdoor assembly and disassembly of scaffolding is prohibited in the following conditions:

47.1. At dusk, if the workplace is not adequately illuminated (Total light intensity must be at least 100 lx);

47.2. In case of thick fog, heavy rain, heavy and thick snow, also during storms and In case of thick fog, heavy rain (during rain), heavy and thick snow, as well as during storms and sleet;

47.3. In case of wind speed exceeding 15 m/s (in open places, on elevated or access platforms or other places at height in case of wind speed exceeding 10 m/s).

Requirements for scaffold inspection

48. After the scaffolds are installed the scaffold inspector shall inspect the scaffolds, fill in the scaffold inspection card following the scaffold inspection checklist provided in Annex 2 and put the card on scaffolds in a clearly visible place at every access point (ladders or staircases). A scaffolding company may use scaffold inspection card of another form however it must include all elements and requirements of form provided in Annex 3.

49. A scaffold inspector shall visually inspect scaffolds periodically once per 10 days at least, also each time after reassembly or modification, heavy rain or strong wind, thaw or mechanical impact, and shall make respective entries in the scaffold inspection card in the field 'Periodic scaffold inspection' (Annex 3).

Requirements for scaffold use

50. If access to work platform is fitted with lockable door/hatch, an employee must close and secure it upon climbing onto the work platform.

51. Employees may not use any unsafe scaffolds (with guard rails missing, large gaps between platform decks or presence of any other risks for falls).

52. It is prohibited to carry any tools, equipment and/or materials in hands when ascending the ladders to get on the scaffolds – they must be carried in solid bags/boxes, lifted using ropes.

53. Tools used in places of risk of fall from height must be secured to prevent fall from height (see Fig. 6 for examples).



Fig. 6. Examples of fastening

54. Small items such as nuts, screws, tools, etc. that do not obstruct movement may be kept on scaffold platforms in boxes, bags, etc.

55. If the scaffold inspection card is marked with such inscriptions as 'Dangerous places marked', 'Use fall protection equipment', the employee working on the scaffolds must use PFPE and fasten them to ensure protection against fall from height.

56. In case of use of electric equipment on scaffolds, an employee shall make sure the scaffolds have been grounded and undertake precautions to prevent any damage to power cables and wires: it is prohibited to pull, kink or twist the cables, place any loads on them, to cross with other cables, gas welding hoses, etc.

57. Access to and work on mobile scaffolds is allowed with wheels blocked only. When scaffold is put in the required position, wheels must be blocked before employees start ascending to prevent any displacement or movement. Mobile scaffold may be moved to another place only after all employees exit it.

58. Scaffold users shall not reassemble the scaffolds, remove structural elements thereof or make any other structural changes to scaffolds, or use additional loads on the scaffolds:

58.1. In case of the need to make any changes in the scaffold structure / location with work in progress, a scaffold user shall call for employees of the scaffolding company (the phone number of the contact person is provided in the scaffold inspection card) – only the employees of this company can make changes in, inspect and give permission for use of scaffolds according to the procedure established herein;

58.2. Where use of additional loads on a scaffold is intended (suspending winches, attaching elevators to bring materials onto a working platform, etc.), the permission from a relevant scaffolding company shall be obtained by scaffold users. For this purpose, the work manager of scaffold users shall execute a permit for additional loads (a sample form of permit is provided in Annex 8 hereto) and draw a diagram of the scaffold indicating the locations of additional loads. The diagram shall specify the scaffold registration number and shall be signed by the work manager and responsible representative of the scaffolding company. The permit to use additional loads and the diagram shall be kept together with the work permit at the worksite.

59. Outdoor use of scaffolding is prohibited in the following conditions:

59.1. At dusk, if the workplace is not adequately illuminated (total light intensity must be at least 100 lx);

59.2. In case of thick fog, heavy rain, heavy and thick snow, also during storms and In case of thick fog, heavy rain (during rain), heavy and thick snow, as well as during storms and sleet;

59.3. In case of wind speed exceeding 15 m/s (in open places, on elevated or access platforms or other places at height in case of wind speed exceeding 10 m/s).

Requirements for scaffold demounting

60. Scaffolds shall be demounted only by scaffolders from the company that installed such. When demounting, scaffolders shall follow the requirements prescribed by scaffold manufacturer.

61. Before demounting the scaffolds, scaffolders shall remove scaffold inspection card (Annex 3) and put a sign prohibiting the use of scaffolds (Annex 5).

62. Scaffolds shall be demounted starting from the top section. During demounting the stability of a scaffold structure shall be assured when disengaging the couplers. It is prohibited to throw any scaffold elements down from the top.

63. The damaged parts of scaffold elements shall be sorted out and removed from service.

VIII. LADDERS

Requirements for use of ladders

64. Portable ladders must meet the requirements of the standards LST EN 131-1 [3.8], LST EN 131-2 [3.9], LST EN 131-3 [3.10] and must be used in accordance with the manufacturer's instructions for use; fixed ladders must comply with the standard LST EN 14122-4:2002 [3.12].

65. Portable ladders must be clean, placed on an even, horizontal, firm and stable surface.

66. Single-piece ladder must:

- 66.1. Have anti-slip tips and be fastened before use (tied or secured with a stabilizer);
- 66.2. Protrude at least 1 meter over the landing area;
- 66.3. Lean at an angle of 65°-75°.
- 67. An employee working on a single-piece ladder at the height of over 1 m above the surface on which the ladder has been placed shall use PFPE.
- 68. Portable ladder security locks (if any) must be firmly locked prior to use.
- 69. Portable ladders placed on pathways, exits, passages or where they might be moved because of works performed around them shall be secured or fenced off in order to redirect the traffic or works performed around away from the ladders.
- 70. Portable ladders cannot be used to lift any loads or materials.
- 71. There must not be more than one person on a portable ladder at the same time. If a job requires more than one person, a scaffold or a second ladder must be used.
- 72. The employee ascending or descending a ladder shall be facing the ladder and holding a firm grip maintaining a three-point contact, i.e. both feet and one hand or two hands and one foot, keep hands free.
- 73. An employee working on a portable ladder must:
 - 73.1. Not exceed the maximum bearing load set by the manufacturer for this type of ladder;
 - 73.2. Keep both feet on a step while standing on ladder;
 - 73.3. Keep tools in special belts with pockets and integral lanyards. Secure tools against fall from height by means of lanyards;
 - 73.4. Work with one hand while holding to the ladder with another hand;
 - 73.5. Not stretch out further than at an arm's distance;
 - 73.6. Not ascended to a height beyond the fourth step from the top of the ladder to ensure appropriate support while working;
 - 73.7. Undertake additional precautions when ladder is placed in front of door or passage (lock the door or bar the passage) to prevent any displacement or movement.
- 74. When on a ladder the following is prohibited:
 - 74.1. Work close to any elements under voltage, unless protected against accidental contact with such;
 - 74.2. Work close to rotating parts of equipment such as shafts, pulleys, operating machinery, moving belts;
 - 74.3. Work under any additional risks resulting from exposure to materials present or used, e.g. with acids, alkalis, hot bitumen, etc.;
 - 74.4. Use of any electrical equipment when on a single-piece portable ladder;
 - 74.5. Any work which requires much physical effort and when there is risk of fall or displacement of ladder.
- 75. Work on ladders is allowed for maximum 30 minutes. If the work has to take more than 30 minutes, personnel rotation is required or ladders with working platforms shall be used (see Fig. 6). Such ladders shall also be used when both hands must be kept free for work.



Fig. 6. Ladder with work platform

- 76. For access to confined spaces rope ladders are allowed. Rope ladder must have manufacturer's certificate as well as user and maintenance instructions – instructions of ladders

owned by the Company must be made in Lithuanian language and ladders owned by Contractor – in language of the Contractor.

77. User of rope ladder shall:

77.1. Before use, secure rope ladder to fixed structural elements in the manner specified by the manufacturer to ensure that it cannot become untied or loose.

77.2. Before use, visually inspect rope ladder to make sure it is properly secured and has no broken strands, broken or deformed rungs or other damaged components;

77.3. Use PFPE attached to the lifeline. It is prohibited to attach a lifeline and a ladder rope to the same anchor point. The lifeline must be monitored by another employee at all times. It is prohibited to ascent/descend the ladder by more than one person at the same time.

Requirements for record-keeping, inspections and labeling

78. The record-keeping, inspection and labeling of portable ladders must be carried out in accordance with the requirements of the Company Occupational Health and Safety Procedure BDS-4 Maintenance of Work Equipment (hereinafter – Procedure BDS-4).

79. Ladders shall be inspected periodically according to the procedure and periodicity established in the manufacturer's documentation. If not specified otherwise by the manufacturer, the ladder must be inspected at least once a year in accordance with the requirements of the Procedure BDS-4. When the ladder is inspected, it must be attached with a label with indicated ladder ID number and the date of the next inspection (year and month) (Annex 6 thereto). The ladder can be used only until the beginning of the month of the year indicated in the label.

80. Ladders, which are no longer suitable for use, must be labeled as shown in Annex 7 thereto and removed from the workplace.

IX. MOBILE ELEVATING WORK PLATFORMS (MWP)

Requirements for MWP use

81. MWP shall be used, inspected and maintained according to Operation and Maintenance Manual of Mobile Work Platforms [3.4].

82. MWP can be operated and people can be lifted by trained and certified operator following the procedure established by the owner of MWP. If operator gained knowledge and skills in another member state of European Union the supporting documentation must be held.

83. The Company's employees operating MWP shall be trained and certified as prescribed by Company's Mandatory Employee Training Procedure. Contractor's employees operating MWP shall be trained and certified in accordance with the contractor's procedures. Employees operating MWP shall undergo medical examination and hold the conclusion of medical institution that they can work at height.

84. Employee working in the work platform shall:

84.1. Act as instructed by MWP work manager and MWP operator;

84.2. Enter/exit work platform only in designated access point. Upon entry, immediately fasten the lanyard to the designated anchoring point. It is prohibited to fasten lanyards to building structures or other objects outside the work platform;

84.3. It is prohibited to step on the guard rails of the lifted work platform and other structures, relocate lifted work platform using physical force, lean over the guard rails of the work platform, climb over from the work platform to the building structures or other objects, use elevations, ladders and other similar means, throw tools, materials and other objects from the work platform;

84.4. If MWP is operated from control panel installed in the work platform, according to instructions given by operator stop the platform after it is lifted about 0.2–0.3 m high and make sure that breaks or hydraulic devices are functioning properly;

84.5. Control work platform elevation and operation process and communicate with MWP operator using predefined signs or messages on the progress, warn on any dangerous approach to obstacles;

85. It is prohibited to lift employees and/or loads, if combined weight of people and load exceeds the bearing load of MWP.

Requirements for record-keeping, inspection and labeling of MWP

86. Record-keeping, inspection and labeling of MWP must be performed in accordance with the Rules of Maintenance of Mobile Elevating Work Platforms [3.4].

X. PERSONAL FALL PROTECTION EQUIPMENT (PFPE)

Requirements for PFPE use

87. The PPEF used at the Company shall meet key requirements of EU standards related to health and safe use: bear manufacturer's identification, CE marking, designations referring to the type of protection (respective EN standard), information on specific characteristics, serial number and date of manufacture. Body wear (harness) shall be with D-rings; energy absorbers, lanyards, self-retracting life-lines shall be used with dual action self-locking snap hooks.

88. Employees working on the scaffolds, where inspection card is marked with inscription 'Use fall protection equipment', on 1 m and longer single-piece portable ladder, MWP, on the roofs and other elevated surfaces when there is a risk of fall from height, for fall protection shall use work restraint PFPE.

89. Work positioning PFPE can be used only by specially trained employees holding a certificate from the training institution.

90. If work positioning PFPE is used:

90.1. It must be fastened to an anchoring point which is as high as possible over the employee's working position to make the distance of free fall as small as possible. Elements of steel structures, beams, pipes withstanding the loads of 2 tons at least may be used for anchoring;

90.2. Path of potential fall must be free of any extra objects to prevent any injury in contact. Positioning device must reduce the potential of free fall to a safe distance. In case of failure of positioning system, an employee would suffer severe or fatal injuries. To prevent this, safe distance of free fall must be assured. Safe distance is the distance between the anchor point and obstacles that can cause severe injuries in contact. Safe distance is calculated by considering the parameters of shock-absorbing devices and the position of the anchoring point (see Fig. 8);

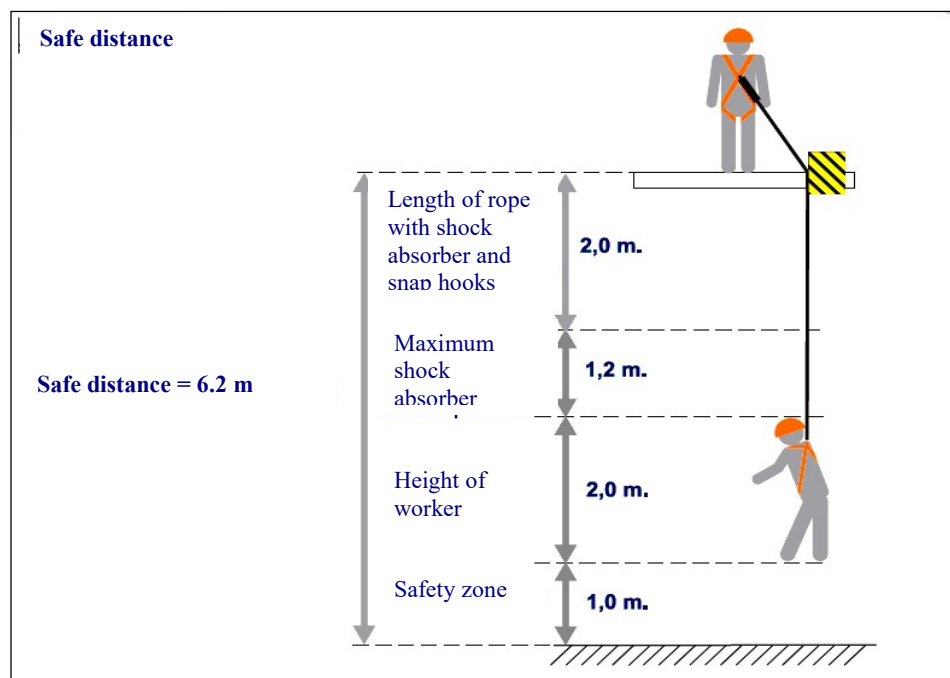

Fig. 8. Safe distance

90.3. An anchoring point must be selected to prevent a swing fall (pendulum effect), when a worker whose fall has been arrested swings from side to side, possibly striking equipment,

material, or a structure which may cause injuries. The angle of a swing from an anchor point cannot exceed 30° (see Fig. 9).

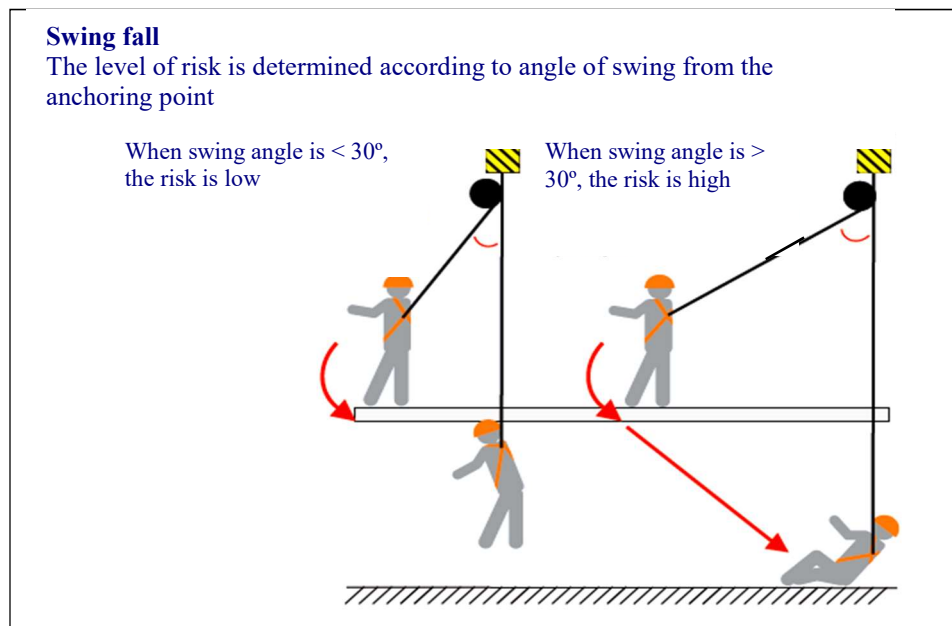

Fig. 9. Swing fall

91. Where work at height involves walking and work standing on elevated structures or elements thereof, and where use of scaffolds or any other equipment is inexpedient, horizontal safety systems may be used. Such systems used at the Company must meet requirements set in §86 of this Procedure. Employees using such systems for work must familiarize themselves with manufacturer's user manuals and observe requirements prescribed there.

Requirements for storage and maintenance of PFPE

92. PFPE shall be stored and maintained according to manufacturer's user manuals.

93. Elements of equipment made of artificial fiber must be protected against exposure to direct sunlight, sources of heat, aggressive substances, kept hung up in a dry and moderately warm room.

94. PFPE must be cleaned using proper cleaning agents (e.g. special industrial cleaners).

Requirements for record-keeping, inspection and labeling of PFPE

95. Record-keeping, inspections and labeling of PFPE must be performed in accordance with the Procedure BDS-4.

96. Each piece of PFPE and its specific element must undergo periodic inspection at least once per year (unless otherwise prescribed by the manufacturer).

97. A manager of an organizational unit of the Company or of contractor whose employees use PFPE must take into account the conditions in which equipment is used. In case of heavy use, use in aggressive environment and/or under extreme weather conditions, in order to ensure reliability of PFPE a manager must arrange for inspections at shorter intervals than prescribed by the manufacturer.

98. During periodic inspections PFPE is examined in detail as prescribed by the manufacturer. Periodic inspections can be performed by a competent person only according to procedure prescribed by the manufacturer.

99. Periodic inspections must be recorded therefore together with equipment presented for inspection its identification card (certificate) must be submitted as well. The findings of inspection shall be executed in the form of inspection report and respective entries in the certificate (or

identification card) of equipment and in the logbook shall be made. The reports shall include: the type and name of inspected equipment, designation of the specific standard, identification data (serial number, date of manufacture, start of use (date), last inspection date), the date of the current inspection, and conclusion of inspection: fit for use through to (date of next inspection), or unfit for use – indication of reasons, the owner, the executor, the executor's signature and a copy of qualification certificate. Equipment certificate (identification data card) shall be stored all through the period of use of the equipment.

100. When PFPE is inspected, it must be attached with a label with indicated PFPE identification number and the date of the next inspection (year and month) (Annex 6 thereto). PFPE can be used only until the beginning of the month of the year indicated in the label.

Recognition of PFPE as unfit for use

101. PFPE is unfit for use if:

101.1. It has been used to arrest fall and has been exposed to impact loads (can be further used only after competent person inspects the affected elements and gives permission for further use);

101.2. Any intolerable defect (e.g. damage to belt, lanyard (cuts, tears, burns, etc.), heavy soiling, deformation of connectors, couplers and hooks, surface abrasions across the woven line and in the areas of loops, torn energy absorber, etc.) has been detected during the inspection or there are doubts regarding the condition of equipment;

101.3. Equipment is non-identifiable (label is missing or is illegible);

101.4. There is no data on the mandatory periodic inspection performed;

101.5. The condition of equipment during periodic inspection has been evaluated as unfit for use.

102. PFPE, which are no longer suitable for use, must be labeled as shown in Annex 7 thereto and removed from the workplace.

XI. EMPLOYEE ACTIONS IN CASE OF EMERGENCY

103. Depending on potential risks during work at height, before the commencement of works work manager must establish procedure for rescue of workers and provision of first aid and prepare necessary rescue equipment to be used in case of emergency (gas release, fire, etc.) or fall from height. Work manager must explain these procedures to the workers.

104. If according to pre-established rescue procedure the works will be evacuated through the top opening of confined space, the lifting equipment (tripods, hoists, cranes, etc.) must be installed above the opening or sufficient number of on-duty employees ready to retrieve the workers from the confined space must be ensured.

105. All incidents must be immediately reported by the workers to the Company's dispatcher by phone number 3333 (from landline network) or +370 443 92510 (from any other network) and to the staff of the unit where the works were carried out. If works are executed in Būtingė Terminal, all incidents must be reported to Shift Supervisor of Terminal Operations Group, tel.: +370 443 93459 or +370 686 78112.

106. In the event of fall and ongoing suspension (hanging) in a harness large amounts of blood from higher internal organs, in particular heart, kidney, lungs and brain rushes into parts of body with lower blood circulation. After 5–10 minutes the casualty begins to feel tinnitus, nausea and dizziness. Almost instantly due to lack of blood flow to vital organs such as brain and kidneys the casualty can lose consciousness. It is important for the first aid provider to keep constant contact with the casualty and encourage him/her to move limbs to stimulate the circulation of blood.

107. The casualty must be lowered onto the ground into a sitting position (e.g. leaning against wall) and kept in that position for 20-40 minutes. Only after this period the casualty may be laid on the ground. Otherwise all the stale blood will rush back into the rest of the body in one huge slug and can damage the organs it passes through, most importantly the heart. Anyone who has suffered from suspension trauma must be sent to hospital for a check-up (e.g. for potential kidney damage), even if feeling fine.

108. Employees must be periodically indoctrinated and trained how to rescue the casualty in case of fall from height or suspension trauma and how to operate rescue equipment.

XII. EMPLOYEE TRAINING

109. Scaffold inspectors or scaffolders shall be trained, certified and hold respective documents (certificate, etc.) confirming that they have the qualification to work with the particular type of scaffolds, also indoctrinated on the present Procedure.

110. The Company's employees who organize, plan, control and/or perform works at height shall be trained and indoctrinated under the present Procedure as prescribed by the Company's Occupational Health and Safety Indoctrination Procedure.

111. Training of contractor's employees under the present Procedure shall be organized and held by contractor's manager.

112. The Company employees working at height and using PPEF shall be trained to use PPEF at special training seminars and training institutions.

XIII. FINAL PROVISIONS

113. This Procedure sets only basic and minimum OHS requirements for works at height therefore all employees involved in organizing and/or performing such works must take additional OHS measures if necessary to ensure the safety of workers.

114. Director of Quality, Labour Safety and Environmental Control is responsible for the periodic review, and where necessary updating, of this Procedure.

XIV. ANNEXES

Annex 1. Scaffold diagram with typical elements.

Annex 2. Scaffold inspection memo.

Annex 3. Sample scaffold inspection card.

Annex 4. Classes of scaffolds according to loads and designated purpose.

Annex 5. Signs prohibiting the use of scaffold.

Annex 6. Sample inspection tag.

Annex 7. Sample tag for equipment that is no longer suitable for use.

Annex 8. Sample permit to use additional loads on scaffold.

Prepared by:
Control and Prevention Group Manager
Egidijus Luomanas

Scaffold diagram with typical elements

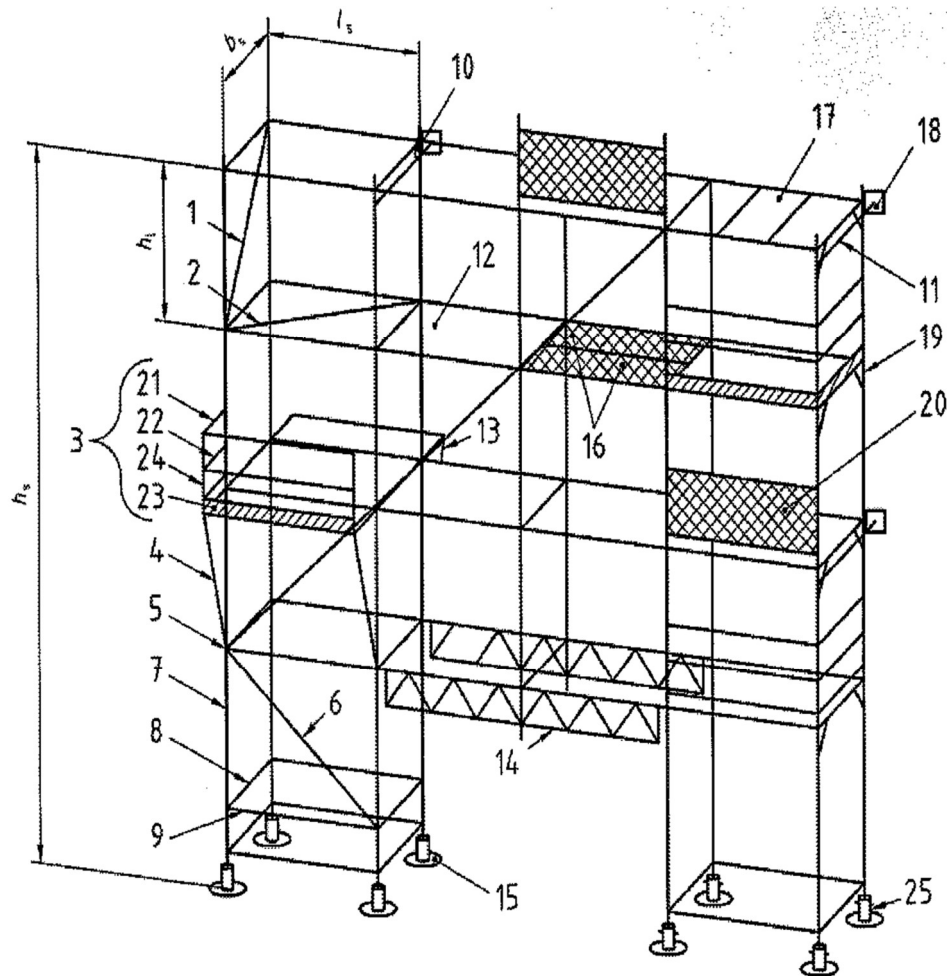

h_s – scaffold height;

b_s – scaffold width between upright centers;

l_s – scaffold length between upright centers;

h_l – scaffold level height;

1 – transverse bracing;

2 – horizontal bracing;

3 – guard rail;

4 – bracket;

5 – coupler;

6 – vertical diagonal brace;

7 – post;

8 – runner (ledger);

9 – bearer;

10 – sleeve coupler;

11 – fastener;

12 – decks;

13 – holder;

14 – double (overlapping) ledger;

15 – base plate;

16 – deck piece (plank, board);

17 – horizontal frame;

18 – anchor;

19 – vertical frame;

20 – fencing;

21 – top rail;

22 – mid rail;

23 – toe board;

24 – post;

25 – base plate sills.

SCAFFOLD INSPECTION CHECKLIST

Requirement	YES	NO	NOT APPLICABLE
Scaffolds are placed on a firm and stable surface			
Scaffold elements are free of any damages, cracks, dents, deformations and any other defects			
Scaffolds are duly leveled both horizontally and vertically			
Scaffolds are fastened using the methods provided in the design or as specified by the manufacturer and are stable			
Transverse bracings are installed on all sides, on all levels and at least in every fifth vertical frame			
Gaps between individual decks, and between deck and toe board is maximum 25 mm			
Guard rails (top and mid-rails as well as a foot board) installed			
The height of the top rail – not less than 1 m			
The distance between the horizontal elements of rails does not exceed 0.5 m			
If access to the work platform is arranged inside the scaffolding structure, the decks with closed lockable access hatches are installed on the work platform			
If access to the work platform is arranged outside the scaffolding structure, the gates are installed for access on the work platform			
Access means to top levels are stable and protected against accidental loosening and displacement			
Work platforms are free of any unnecessary materials, objects, waste, etc.			
NOTE! If NO, remove any irregularities according to requirements prescribed before using the scaffolds.			

SCAFFOLD CLASSES ACCORDING TO LOADS AND PURPOSE

Class 1 scaffolds are intended for inspections and works when light-weighted equipment is used and no materials are placed on scaffolds;

Class 2 and class 3 scaffolds are intended for inspections and works with no materials placed on scaffolds except for the materials instantly used for work, e.g. wrenches, welding rods, washers, bolts & screws, etc.;

Class 4 and class 5 scaffolds are intended for brickwork and similar works;

Class 6 scaffolds are used in cases where large quantities of heavy materials need to be kept on scaffolds.

Working platform loads (acc.to Table 3 of LST EN 12811-1:2006)

Load bearing class	Even distribution of load q_1 , kg/m^2	Concentrated load onto the area of 500 mm x 500 mm F_1 , kg	Concentrated load onto the area of 200 mm x 200 mm F_2 , kg	Load on platform part	
				q_2 , kg/m^2	Coefficient of platform part
1	75	150	100	-	-
2	150	150	100	-	-
3	200	150	100	-	-
4	300	300	100	500	0.4
5	450	300	100	750	0.4
6	600	300	100	1000	0.5

Each working platform must withstand individual rather than simultaneous loads q_1 , F_1 and F_2 . The load on the base of scaffold q_1 must be distributed evenly.

All elements of decks of class 1 scaffolds must withstand operating loads of class 2 however this does not apply to the entire scaffold assembly.

The forces resulting from loads must be transferred to posts.

Signs prohibiting use of scaffolds (examples)



Sample inspection tag

Verified  **ID No**

OPERATION PERMITTED UNTIL:

Year	2024	2025	2026	2027
-------------	-------------	-------------	-------------	-------------

Month	1	2	3	4	5	6	7	8	9	10	11	12
--------------	----------	----------	----------	----------	----------	----------	----------	----------	----------	-----------	-----------	-----------

Sample tag for equipment that is no longer suitable for use

Front side of the tag



Reverse side of the tag



PERMIT TO USE ADDITIONAL LOADS ON SCAFFOLD
(Form)

Scaffold registration number: _____

Location of scaffold: _____

(Organizational unit, name and tag number of equipment, pipeline, etc.)

Additional loads: _____

(to suspend winches for rigging, secure hoists for lifting materials onto scaffold, etc.)

Maximum weight of additional loads: _____ kg

Time of use of additional loads: from _____ to _____

Scaffold user:

(Company using the scaffolds, work manager's full name, signature and mob. phone number)

Additional loads permitted:

(Scaffolding company, responsible person's position, full name, signature and mob. phone number)

Scaffold diagram with indicated locations of additional loads: